

B-SYSTEM

INSTALLATION SOLUTIONS

Wallboxx

2nd Generation

Datasheet



Installation
Video

Suitable for small 4 inch in-wall speakers with a maximum installation depth of 112,5 mm!

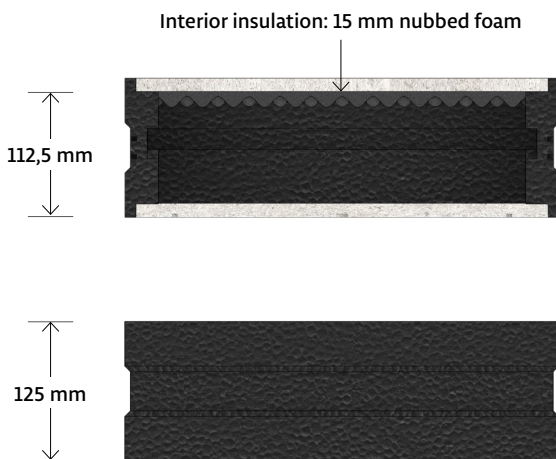
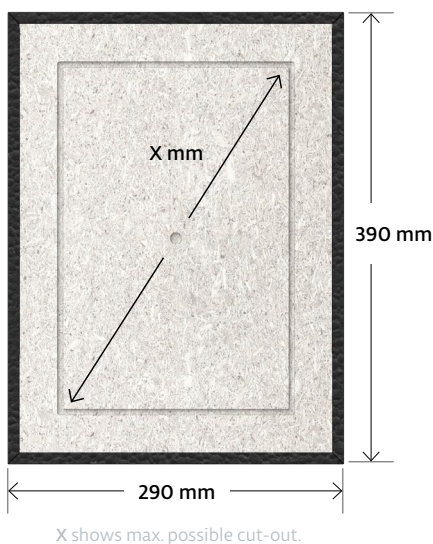
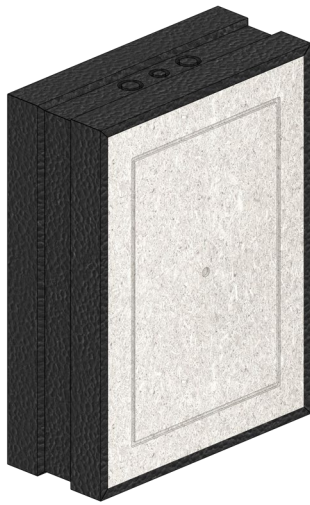

Description

Wallboxx: universal installation box for brick and concrete walls.

Front and rear made of quartz-coated OSB panels, seamlessly integrating into the installation workflow for easy further processing of the wall surface. The base body is made of EPS and features low-resonance and sound-insulating properties.

Features and benefits

- modular product, available in seven standard sizes
- front and rear walls made of quartz-coated OSB boards (12 mm)
- fixed break-out points for optimal installation of electrical conduits (20 mm + 25 mm)
- interior insulation foam, grey (15 mm)
- low weight and high stability with excellent vibration damping compared to other enclosures
- better audio reproduction than other enclosures made of wood, sheet metal or plastic
- better air and structure-borne sound insulation than conventional installation backboxes



- Prefabricated cut-outs available ex works
- Special sizes on request

Scope of supply (per piece)

- 1 Wallboxx XS
- 1 Installation guide
- 1 Cardboard packaging

Type	Wallboxx XS
SKU	1001210
Dimensions	390 × 290 × 125 mm (L × W × H)
Installation depth	112,5 mm
Cut-out dimension X	max. 290 × 190 mm (L × W)
Internal volume	7,60 l
Fire protection classification	B1
Pallet unit	56 pieces
Pallet dimensions	120 × 80 × 204 cm



Video installation guide

<https://b-system.com/wallboxx-qr>

Suitable for small 4 inch in-wall speakers with a maximum installation depth of 112,5 mm!

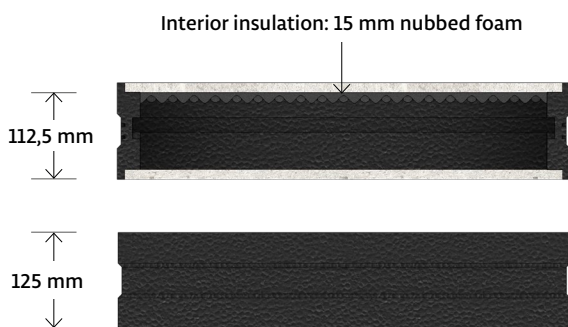
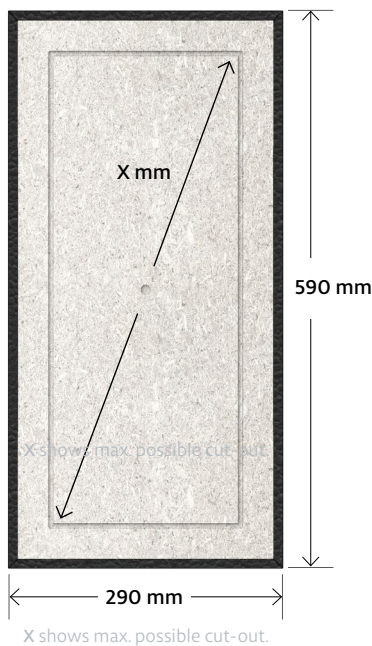
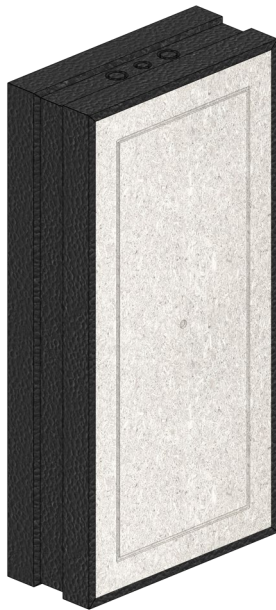

Description

Wallboxx: universal installation box for brick and concrete walls.

Front and rear made of quartz-coated OSB panels, seamlessly integrating into the installation workflow for easy further processing of the wall surface. The base body is made of EPS and features low-resonance and sound-insulating properties.

Features and benefits

- modular product, available in seven standard sizes
- front and rear walls made of quartz-coated OSB boards (12 mm)
- fixed break-out points for optimal installation of electrical conduits (20 mm + 25 mm)
- interior insulation foam, grey (15 mm)
- low weight and high stability with excellent vibration damping compared to other enclosures
- better audio reproduction than other enclosures made of wood, sheet metal or plastic
- better air and structure-borne sound insulation than conventional installation backboxes



- Prefabricated cut-outs available ex works
- Special sizes on request

Scope of supply (per piece)

- 1 Wallboxx S
- 1 Installation guide
- 1 Cardboard packaging

Type	Wallboxx S
SKU	1001220
Dimensions	590 × 290 × 125 mm (L × W × H)
Installation depth	112,5 mm
Cut-out dimension X	max. 490 × 190 mm (L × W)
Internal volume	12,60 l
Fire protection classification	B1
Pallet unit	56 pieces
Pallet dimensions	120 × 80 × 204 cm



Video installation guide

<https://b-system.com/wallboxx-qr>

Wallboxx M

2nd Generation

Suitable for medium-sized 6-8 inch in-wall speakers with a maximum installation depth of 112,5 mm!

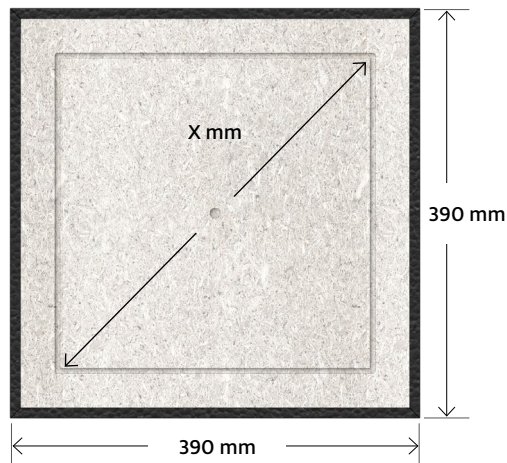
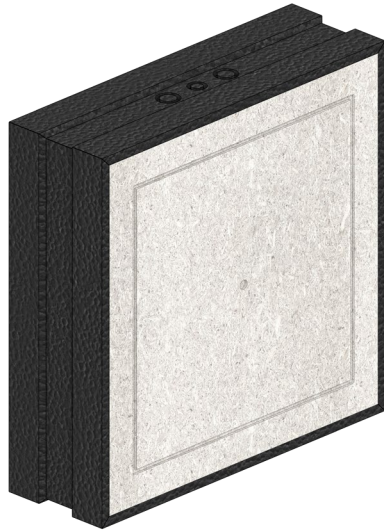

X shows max. possible cut-out.

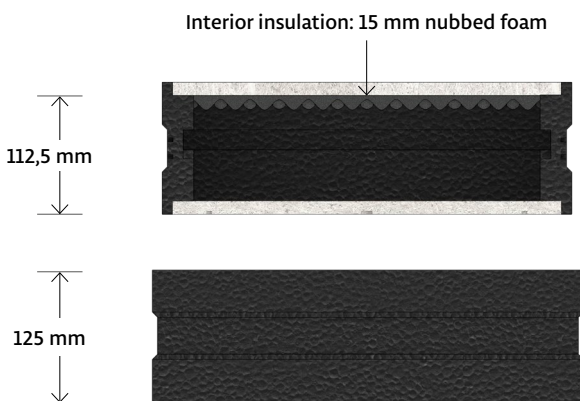

Datasheet

Description

Wallboxx: universal installation box for brick and concrete walls.

Front and rear made of quartz-coated OSB panels, seamlessly integrating into the installation workflow for easy further processing of the wall surface. The base body is made of EPS and features low-resonance and sound-insulating properties.

Features and benefits

- modular product, available in seven standard sizes
- front and rear walls made of quartz-coated OSB boards (12 mm)
- fixed break-out points for optimal installation of electrical conduits (20 mm + 25 mm)
- interior insulation foam, grey (15 mm)
- low weight and high stability with excellent vibration damping compared to other enclosures
- better audio reproduction than other enclosures made of wood, sheet metal or plastic
- better air and structure-borne sound insulation than conventional installation backboxes



- Prefabricated cut-outs available ex works
- Special sizes on request

Scope of supply (per piece)

- 1 Wallboxx M
- 1 Installation guide
- 1 Cardboard packaging

Type	Wallboxx M
SKU	1001230
Dimensions	390 × 390 × 125 mm (L × W × H)
Installation depth	112,5 mm
Cut-out dimension X	max. 290 × 290 mm (L × W)
Internal volume	11,40 l
Fire protection classification	B1
Pallet unit	56 pieces
Pallet dimensions	120 × 80 × 204 cm



Video installation guide

<https://b-system.com/wallboxx-qr>

Suitable for large 6-8 inch in-wall speakers with a maximum installation depth of 112,5 mm!

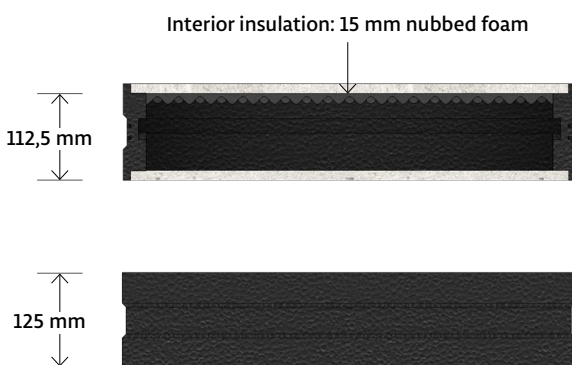
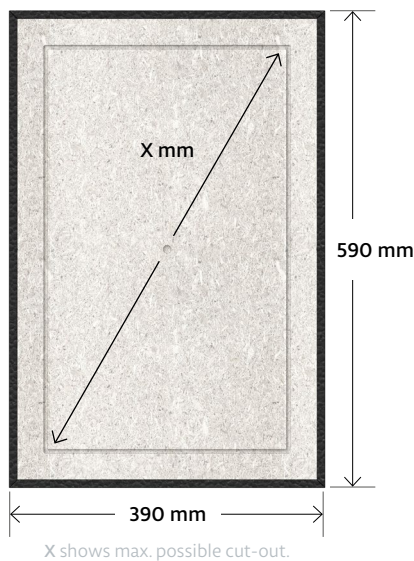

Description

Wallboxx: universal installation box for brick and concrete walls.

Front and rear made of quartz-coated OSB panels, seamlessly integrating into the installation workflow for easy further processing of the wall surface. The base body is made of EPS and features low-resonance and sound-insulating properties.

Features and benefits

- modular product, available in seven standard sizes
- front and rear walls made of quartz-coated OSB boards (12 mm)
- fixed break-out points for optimal installation of electrical conduits (20 mm + 25 mm)
- interior insulation foam, grey (15 mm)
- low weight and high stability with excellent vibration damping compared to other enclosures
- better audio reproduction than other enclosures made of wood, sheet metal or plastic
- better air and structure-borne sound insulation than conventional installation backboxes



- Prefabricated cut-outs available ex works
- Special sizes on request

Scope of supply (per piece)

- 1 Wallboxx L
- 1 Installation guide
- 1 Cardboard packaging

Type	Wallboxx L
SKU	1001240
Dimensions	590 × 390 × 125 mm (L × W × H)
Installation depth	112,5 mm
Cut-out dimension X	max. 490 × 290 mm (L × W)
Internal volume	18,00 l
Fire protection classification	B1
Pallet unit	28 pieces
Pallet dimensions	120 × 80 × 204 cm



Video installation guide

<https://b-system.com/wallboxx-qr>

Suitable for large 6-8 inch in-wall speakers with a maximum installation depth of 112,5 mm!

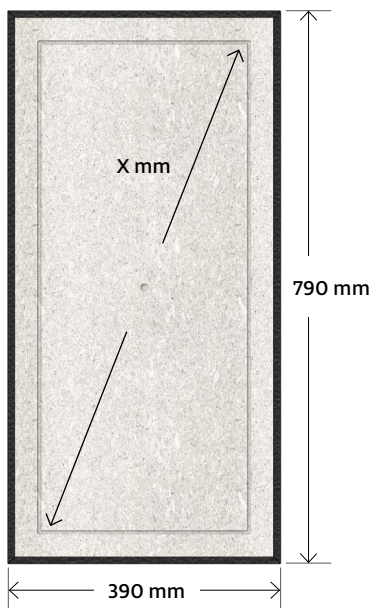

X shows max. possible cut-out.

Interior insulation: 15 mm nubbed foam

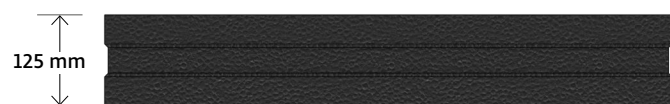
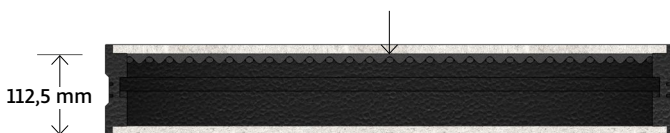

Description

Wallboxx: universal installation box for brick and concrete walls.

Front and rear made of quartz-coated OSB panels, seamlessly integrating into the installation workflow for easy further processing of the wall surface. The base body is made of EPS and features low-resonance and sound-insulating properties.

Features and benefits

- modular product, available in seven standard sizes
- front and rear walls made of quartz-coated OSB boards (12 mm)
- fixed break-out points for optimal installation of electrical conduits (20 mm + 25 mm)
- interior insulation foam, grey (15 mm)
- low weight and high stability with excellent vibration damping compared to other enclosures
- better audio reproduction than other enclosures made of wood, sheet metal or plastic
- better air and structure-borne sound insulation than conventional installation backboxes



- Prefabricated cut-outs available ex works
- Special sizes on request

Scope of supply (per piece)

- 1 Wallboxx L+
- 1 Installation guide
- 1 Cardboard packaging

Type	Wallboxx L+
SKU	1001250
Dimensions	790 × 390 × 125 mm (L × W × H)
Installation depth	112,5 mm
Cut-out dimension X	max. 690 × 290 mm (L × W)
Internal volume	24,70 l
Fire protection classification	B1
Pallet unit	28 pieces
Pallet unit	120 × 80 × 204 cm



Video installation guide

<https://b-system.com/wallboxx-qr>

Suitable for medium-sized LCR in-wall speakers with a maximum installation depth of 112,5 mm!

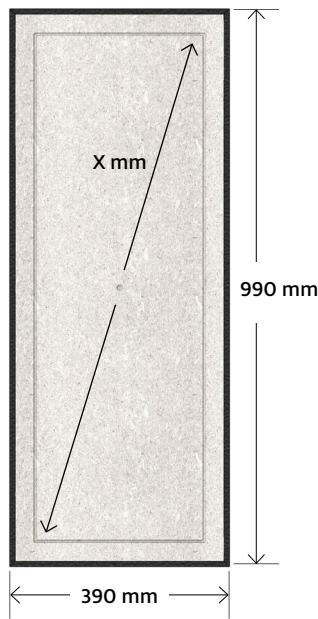

X shows max. possible cut-out.

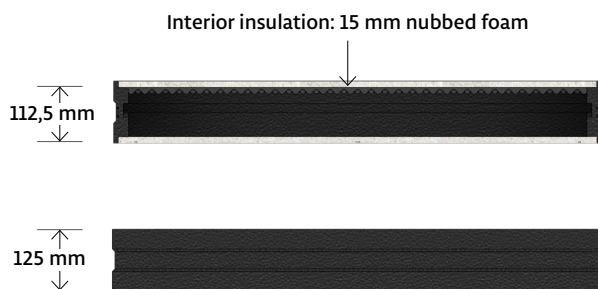

Description

Wallboxx: universal installation box for brick and concrete walls.

Front and rear made of quartz-coated OSB panels, seamlessly integrating into the installation workflow for easy further processing of the wall surface. The base body is made of EPS and features low-resonance and sound-insulating properties.

Features and benefits

- modular product, available in seven standard sizes
- front and rear walls made of quartz-coated OSB boards (12 mm)
- fixed break-out points for optimal installation of electrical conduits (20 mm + 25 mm)
- interior insulation foam, grey (15 mm)
- low weight and high stability with excellent vibration damping compared to other enclosures
- better audio reproduction than other enclosures made of wood, sheet metal or plastic
- better air and structure-borne sound insulation than conventional installation backboxes



- Prefabricated cut-outs available ex works
- Special sizes on request

Scope of supply (per piece)

- 1 Wallboxx XL
- 1 Installation guide
- 1 Cardboard packaging

Type	Wallboxx XL
SKU	1001260
Dimensions	990 × 390 × 125 mm (L × W × H)
Installation depth	112,5 mm
Cut-out dimension X	max. 890 × 290 mm (L × W)
Internal volume	31,40 l
Fire protection classification	B1
Pallet unit	24 pieces
Pallet dimensions	120 × 80 × 195 cm



Video installation guide

<https://b-system.com/wallboxx-qr>

Suitable for large LCR in-wall speakers with a maximum installation depth of 112,5 mm!

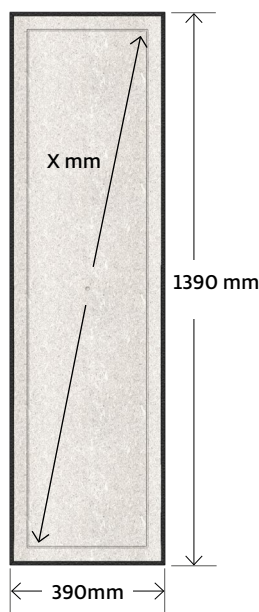

X shows max. possible cut-out.

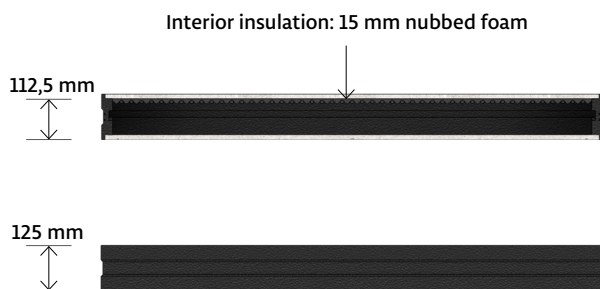

Description

Wallboxx: universal installation box for brick and concrete walls.

Front and rear made of quartz-coated OSB panels, seamlessly integrating into the installation workflow for easy further processing of the wall surface. The base body is made of EPS and features low-resonance and sound-insulating properties.

Features and benefits

- modular product, available in seven standard sizes
- front and rear walls made of quartz-coated OSB boards (12 mm)
- fixed break-out points for optimal installation of electrical conduits (20 mm + 25 mm)
- interior insulation foam, grey (15 mm)
- low weight and high stability with excellent vibration damping compared to other enclosures
- better audio reproduction than other enclosures made of wood, sheet metal or plastic
- better air and structure-borne sound insulation than conventional installation backboxes



- Prefabricated cut-outs available ex works
- Special sizes on request

Scope of supply (per piece)

- 1 Wallboxx XXL
- 1 Installation guide
- 1 Cardboard packaging

Type	Wallboxx XXL
SKU	1001270
Dimensions	1390 × 390 × 125 mm (L × W × H)
Installation depth	112,5 mm
Cut-out dimension X	max. 1290 × 290 mm (L × W)
Internal volume	44,80 l
Fire protection classification	B1
Pallet unit	24 pieces
Pallet dimensions	148 × 80 × 195 cm



Video installation guide

<https://b-system.com/wallboxx-qr>

B-SYSTEM

INSTALLATION SOLUTIONS

B-SYSTEM GmbH
Bismarckstraße 19
78652 Deisslingen
Germany

Phone: +49 (0)7420 889-889
E-mail: info@b-system.com
Web: www.b-system.com